

## سامر مظهر قنطجبي /

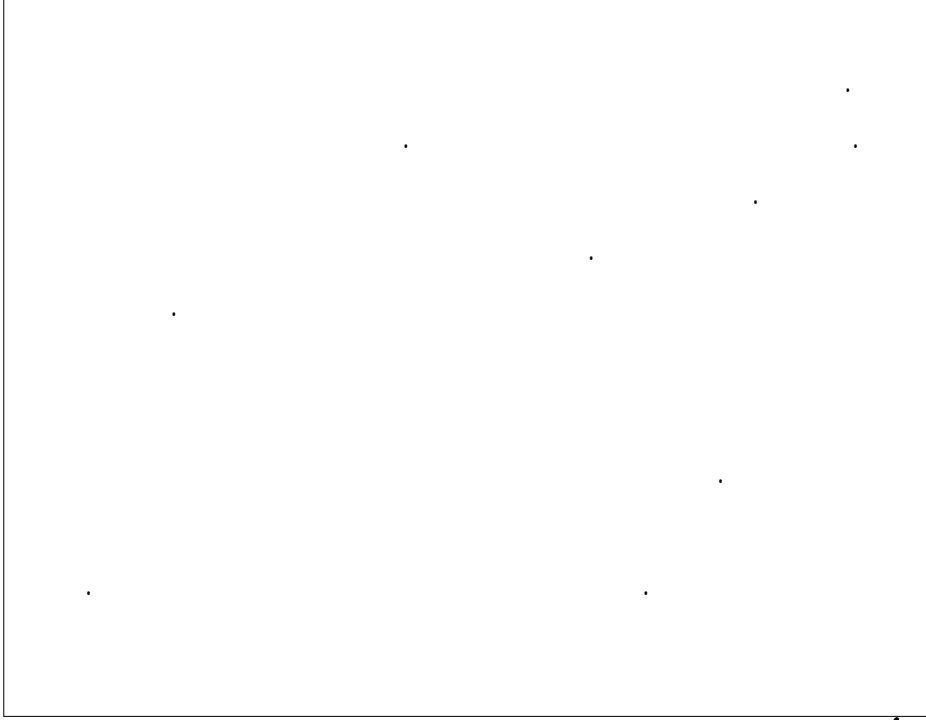

موضوع البحث وأهميته

# المبحث الأول: الصيانة في صناعة الإسمنت

:

( )

:( - )

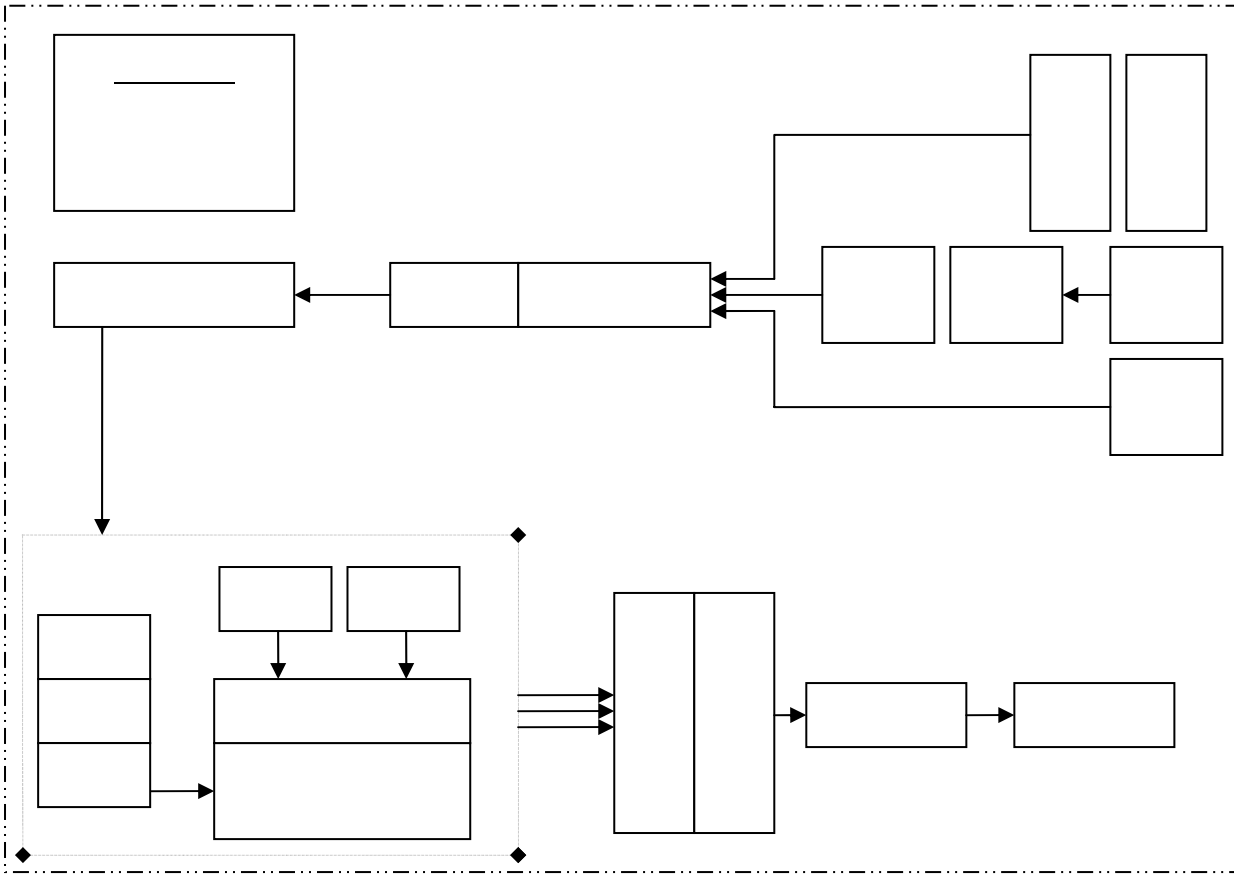

( - )

:

:

-

( ) ( ) :

: -

: -

: - -

---

: .

-

-

-

:

-

-

( )

-

( )

-

-

-

.( - )

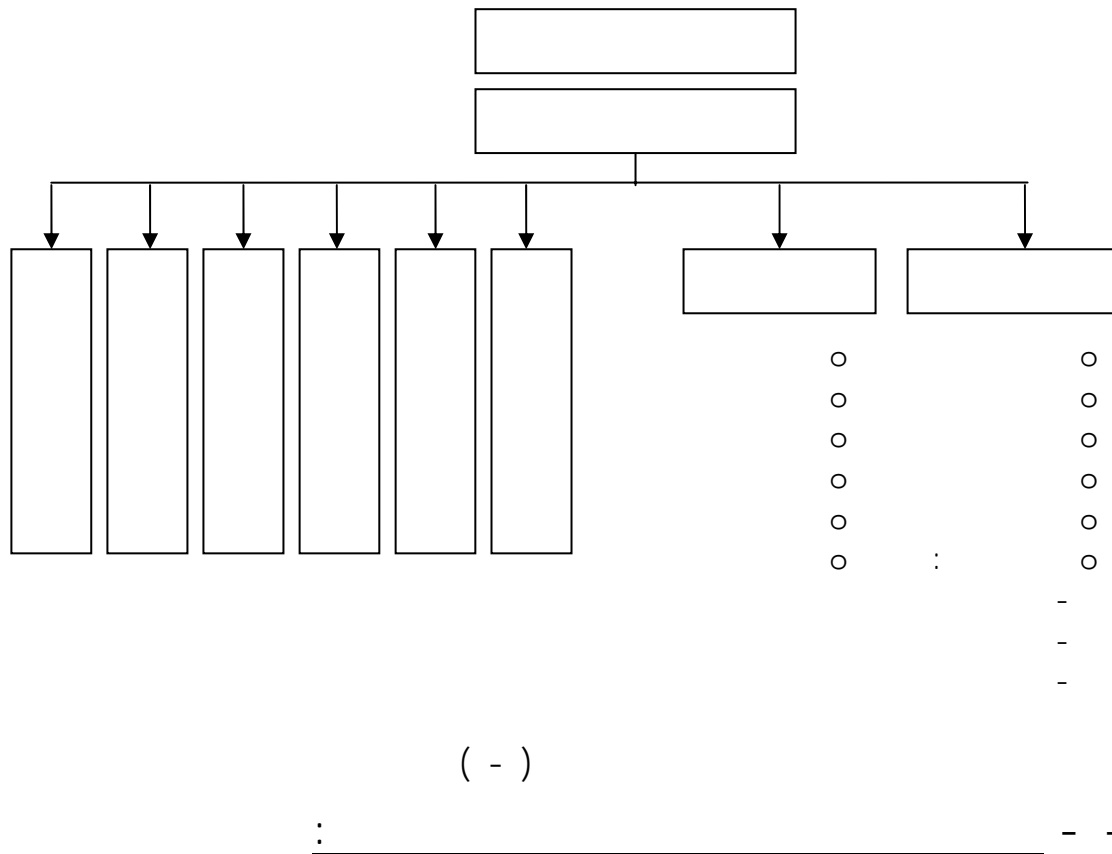

.( - ) .

---

<sup>1</sup> Oest, Flemming - (Development of Organizational Structures in Cement Plant), OP.CIT., PP.2.

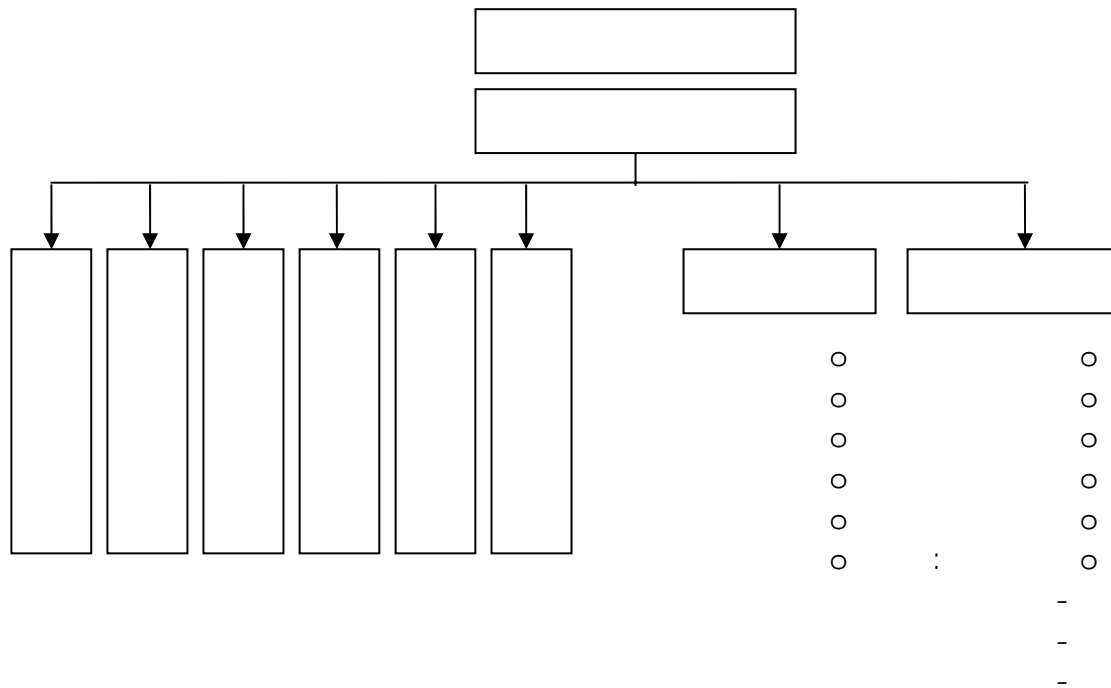

( - )

( - )

:( - )

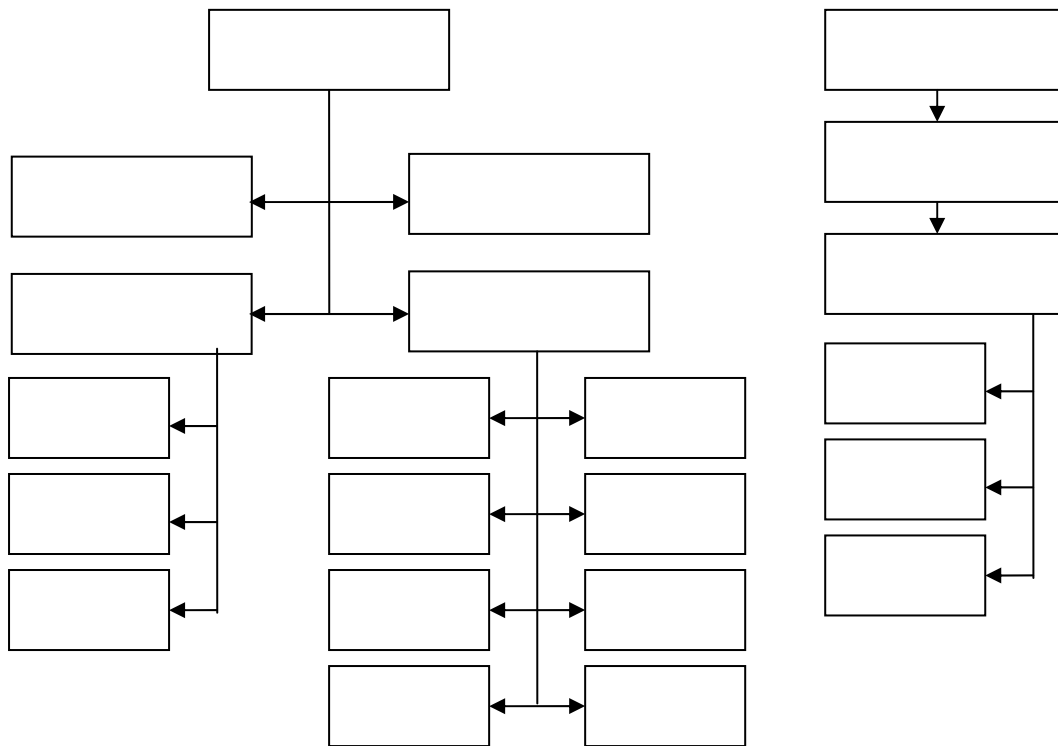

( - )

-  
-  
-

:

.  
.



:  
-  
-  
-  
-

( : )

)

.(

.( )

.( - )

:

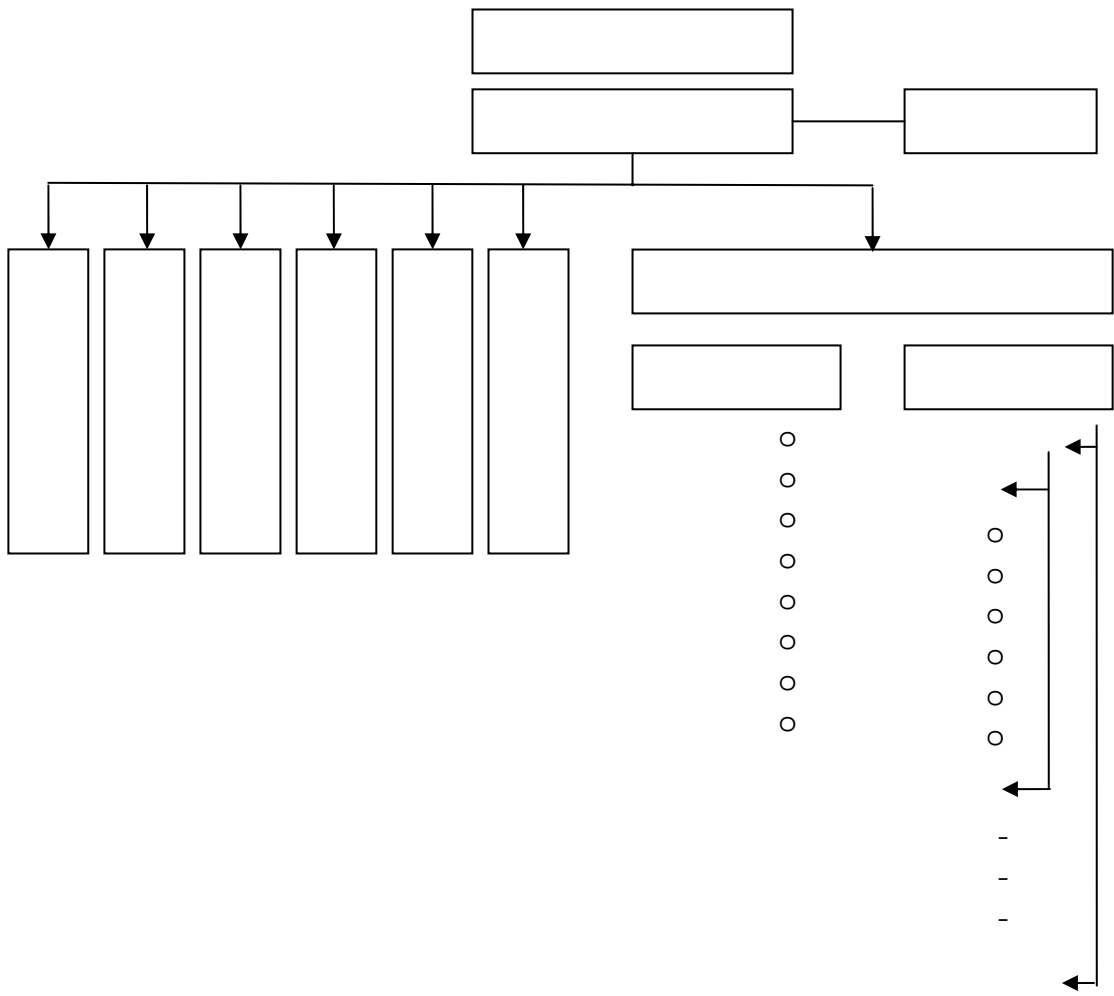

( - )

المبحث الثاني: نموذج حاسوبي لأنظمة الصيانة التي تعتمد الحاسوب<sup>2</sup>

أولاً - مكونات النظام: أجهزة، برامج، بيانات

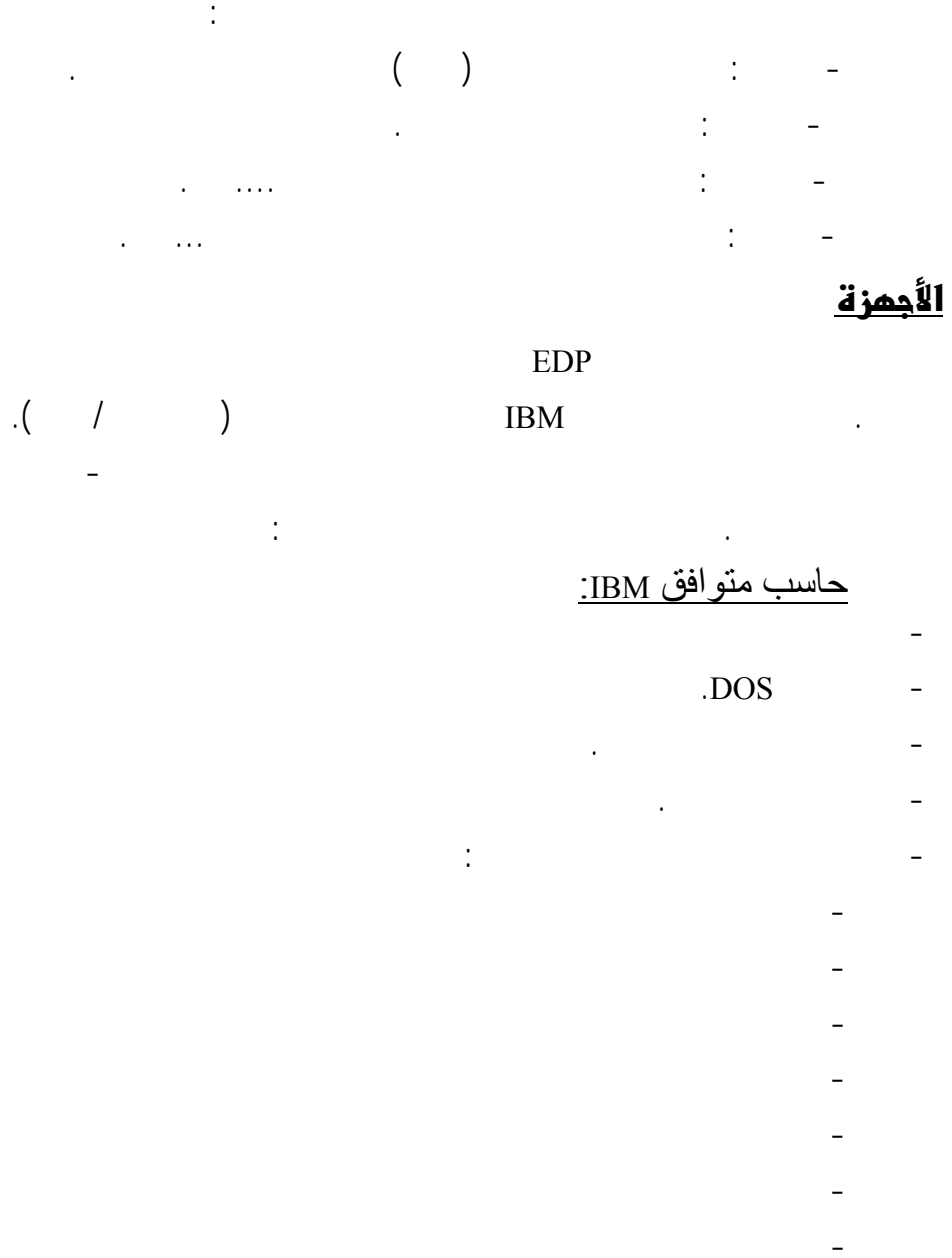

<sup>2</sup> Jan H. Nielsen -1991- (ILLUSTRATION OF A COMPUTERIZED MAINTENANCE SYSTEM WHICH MAY BE DESIGNED TO OPERATE AT VARIOUS FUNCTIONAL LEVELS) - F.L.Smith, Denmark ,PP. 36.

**البرمجيات**

UNIX,NOVEL

PC

DOS

**التطبيقات**

EDP

...

-  
-  
-  
-  
-  
-

EDP

---

**البيانات**

EDP

FLS

FLS

**تضمينات**

:- \_\_\_\_\_

:- \_\_\_\_\_

:- \_\_\_\_\_

:- \_\_\_\_\_

:- \_\_\_\_\_

:- \_\_\_\_\_

( ) .

**ثانياً - وظائف النظام**

% -

:

-

-



:

-

-

:

-

-

-

-

:

-

:

-

:

Model

-

-

:

-

:

-

:

-

# Cement Industry Maintenance Models & a Computerized Model to Maintenance Jobs

Dr. Samer Kantakji / PhD of Accountancy

## Summary

The purpose of this article is to focus on some maintenance management bases, and to apply this basis on the important industry in countries in general, especially in the growing countries, because it is contracting its structural bases. So, productivity in these countries is decreasing, or it is not growing. The main reason is the extra cost of the product, and the maintenance cost is its big part.

These costs are growing while the machines are getting much older. In spite of the fact that maintenance works become more complex and require more specializations, we can not control them by the traditional ways, and by the classic organization of management.

Therefore, the researcher focuses on Cement industry of Hama Cement Factories, which organizes itself by experience, and on Portland Cement of Denmark Factory, which develops its organization by Mathematical and research techniques. Then, the researcher displays a maintenance-computerized model, which is applied in the European companies to achieve the best benefits.

In addition, the researcher recommends applying a maintenance model depending on the computer system. In these systems the maintenance jobs trend to be more efficient and effective. Then the high management can control all the maintenance activities by linking its sub-management relationships in scientific methods. Also it can link its EDP to the computer systems if it is found.

The implementation of the computerized system consists of: flow diagram, critical units, preventive maintenance and spares, work plan, maintenance schedule, and the corrective maintenance.

In spite of this, the system describes and determines the maintenance responsibility, supervisor's work, preventive maintenance activities, lists of the work, inspections, condition control. On-line help supports the level of stocks and spare parts and equipment replacement.

## References

- (1) Jan H. Nielsen -1991- (ILLUSTRATION OF A COMPUTERIZED MAINTENANCE SYSTEM, WHICH MAY BE DESIGNED TO OPERATE AT VARIOUS FUNCTIONAL LEVELS) - F.L.Smith, Denmark, PP. 36.
- (2) Oest, Flemming -1990- (Development of Organizational Structures in Cement Plant), - F.L.Smith, Denmark, PP. 16.