

تاريخ الاستلام : ٢٥/٢/٢٠٠٦ م ، تاريخ قبول البحث ١٥/٥/٢٠٠٦ م

:
(ABC)

-١

-٢

-٣

-٤

Activity Based Costing for Universities

Abstract: The main objective of this research is the effective use of the accounting approach to calculating costs. This approach is based on Activity Based Costing (ABC) which is used in assessing and controlling the cost of educational services; in addition, it provides the necessary data which is used in accurate identification of administrative decision as well as the cost of services provided by universities. In the process of achieving the main objective of the study, the deductive approach has been used while surveying literature review. The same approach has been used to examine the possibility of using ABC in providing the data required to tackle points of

weakness, and in effect, developing and orienting the cost of educational services. Accordingly , the research has reached the following conclusions:

1-It has been found out that the new system can help in overcoming the problems related to the use of the traditional system in; the ABC helps in assessing the indirect cost and determining the average cost of each activity in accordance with the suitable cost stimulators.

2-The ABC can overcome the problems emerging from charging on capitals.

3-Pricing based on ABC is useful in the administration of universities in the sense of raising awareness of cost. This will be reflected on employing the available resources to achieve the desired goals.

4-It is possible to use the target cost in pricing educational services.

: -

(ABC)

.Activity Based Costing

: -

(ABC)

:

-
-
-

-:

.1

.2

.3

: -3

-:

-4

()

-5

-6

(ABC)

:

-

-:

:()

. .

:()

. .2

:()

-

:

-

-

:()

..

:() . ,

:

-1

-2

-3

:

-

(Cost Drivers)

.()

) .

.(

:

-:

()

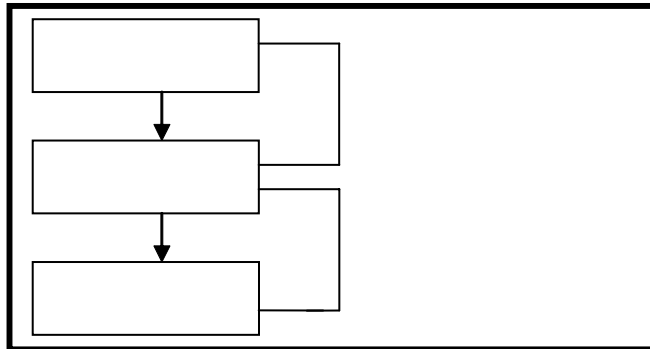

()

:

:

.()

:

-6

.(Damitio & Kintzele, 2000)

-:

:

*

)

.(/)

(/ /

:

:

*

()

:

.1

.2

.3

-:

()

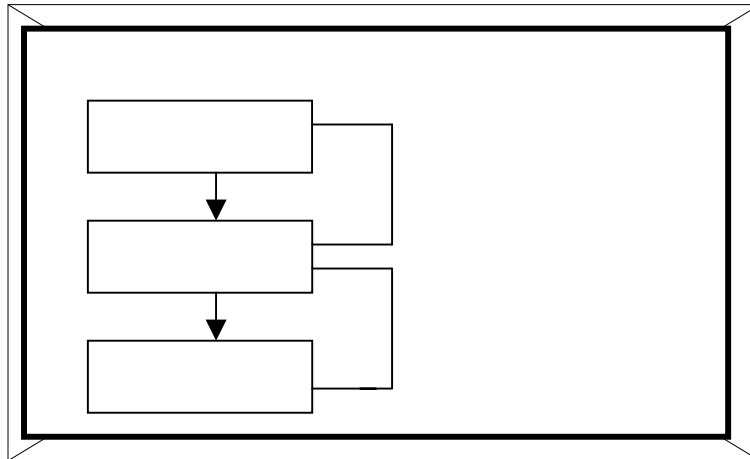

Cooper &)

-: . ,

(Kaplan, 1992

-: . , ,

()

:

-: . , ,

"Hierarchies of Activities"

-(Cooper, 1990)

"Unit Level Activities"

:

/

"Batch Level Activities" :

"Product Sustaining Activities" :

"Facility Sustaining Activities" :

-(John, 1992)

-
-
-

: . . .

: . . .

:

.()

:
.1
.2
.3
.4

Cooper)

-(& Kaplan, 1992

"Transaction Cost Drivers" :

"Duration Cost Drivers" :

()

.(Brimson, 1991)

-(Richardson,2000)

()

()

:

''

:

'''

:

''

-:

)

()

.(

()

-:

-
-
-
-

()

()	()
	-
/ /	-
	-
	-
	-
/ /	-
	-
	-
/	-
	-



.(Woutrs,1996)

-:

:

:

:

..

...

...

Heald &)

.(Scot, 1996

:

()

)

(

)

:

-9

- () (
- -:
- - ·
- " () (
- :" ()
- - :
- :
- 1) Banker, R.D.& Hughes.(1998) Activity Based Costing and Activity Based Management for Health Care, Gaithersburg, MD: Aspen Publishers.
 - 2) Brimson, James A. (1991), Activity Accounting: An Activity Based Costing Approach, New York, John Wiley & Sons Ins.
 - 3) Cooper, Robin (1990) "Cost Classification in unit- Based and Activity Based Manufacturing Cost systems", Journal of Cost Management, Fall: 4-8.
 - 4) Cooper R. & R.S. Kaplan (1992) "Activity Based Costing: Measuring the Costs of Resource Usage", Accounting Horizons, (3):1-13.
 - 5) Damitio Hayes W. Gary & Kintzele L. Philip (2000). "Integrating ABC and ABM at Dow Chemical", Management Accounting, Winter. www.imanet.org
 - 6) Heald D. and David A Scott (1996) "Assessing Capital Charging Health Service " Financial Accountability & Management, August: 224-225.
 - 7) John, Anotos (1992) "Activity Based Management for Sevice, Not for Profit, and Governmental Organizations", Journal of cost Management, Summer 9-12.
 - 8)Richardson, L. Helen (2000), "The New Shape of ABC", Transportation Distribution, Cleveland: May, <http://Proquest.umi.com>.
 - 9) Woutrs, J.F.Maarc (1996). " Why Management Use Cost Allocations: "A Research Note " Accounting & Business Research, Autumn: 341-346.